



ENGINEERED BY



PM-15

2-Way, 15", High Power System

PERFORMING MUSICIAN Series

Description:

The PM-15 Unit is a compact system, offering high Sound Pressure levels in a small foot print.

It has been designed to operate as a two-way passive system. The PM-15 is a multi-angled cabinet, performing as well as a floor monitor or as a small P.A. system. Equipped with a Constant Directivity Mid-High horn, it possesses a simple yet effective way to rotate it, in order to be in the right position when used vertically, (P.A.) or horizontally, (Floor Monitor).

As a P.A. reinforcement unit it can be mounted on a stand, suspended via its built-in tracks or any of its many inserted M-8 threads.

As a floor monitor, it will cover several distances in many different uses thanks to its various angles setting possibilities.

Its dimensions, aiming capacity and coverage have been combined to optimize the performance in each and every possible use.

Together with the different working angles and the rotating horn, the passive filter has been developed to achieve an optimum performance in the range of the vocal spectrum, offering at the same time an effective feed-back control.

The PM-15 can be used on its own without any electronics processing, but has been conceived right from the start and following the current tendencies, to obtain its full musical expression capabilities, through the use of a specific signal processor. Thus, the PM-15 is able to reproduce the deepest bass with utmost purity, expression and safety.



Specifications and characteristics

Frequency Response (Hz) ¹	± 3 dB	56 Hz - 18 KHz
Frequency Range (Hz) ¹	±10 dB	44 Hz - 20 KHz
Nominal Impedance	8 Ohm	
Power Rating	(RMS) ²	700W
	(Program) ²	1400W
	(Peak) ²	2800W
Horizontal Coverage (-6dB)	90°	
Vertical Coverage (-6dB)	40°	
Sensitivity (dB/1W@1m)	98 dB	
SPL Max. Peak (dB SPL@1m) ³	134 dB	
Connectors	2 Neutrik™ NL-4 connectors on steel plate	
Recommended signal processor	RAM Audio LMS-244 / LMS-221 Processor	
Recommended power amp	800W - 1200W RMS@8 Ohm	
Recommended Sub-woofer	SPACE PMS-15 / ARS-215 / ARSO215	

Characteristics:

- Multi-angled unit, designed for Sound Reinforcement or Floor Monitor
- Multi-use Mid-High Constant Directivity, rotatable 90 x 45 degrees Horn
- Active driver "Power Guard" protection without any effective loss
- High Sound Pressure Level, (134dB Peak @ 1m, pink noise with a 6dB crest-factor)
- Rotatable horn and optimized cabinet architecture for monitor and small P.A. uses
- Two-way passive 8 Ohm design to be used with a single power Amp channel per cabinet to obtain an easy assembly and low cost.
- Passive filter which optimizes the voice critical zone response.
- Double input NL-4 Neutrik connector permitting parallel bridging.
- Steel front grille with acoustic foam, easily removable, held in place with powerful Neodymium magnets.
- Suspension Tracks on top and bottom, standard pole cup and thread inserts.
- The specific electronic controller guarantees: linear performance, powerful bass response, reliability.

Components and Enclosure

Components	1 x 15" 700W AES 4" coil
	Driver Neodymium 3" coil 90W AES
Enclosure	Vertical, multi-angle 18mm Baltic cross-ply construction, tongue and groove assembly throughout. Bi-component epoxy finish.
Protection grille	1.5 mm. Laminated steel with textured epoxy finish.
Handle	On the top of the cabinet
Dimensions (H,W,D) mm	700 x 424 x 384
Dimensions (H,W,D) inches	27.5 x 16.7 x 15.1
Net weight	34 Kg. (74.9 pounds)
Rigging	Integrated track rigging system on top and bottom. M-8 inserts for bolt assembly.

Applications:

- Touring, installed P.A., theatres, multi-purpose rooms, etc.
- High performance Monitoring
- When used together with the series' Sub-woofer PMS-15, the system becomes a performing set-up for many dance applications.

¹ Specifications in half space
² With filtered pink noise 6dB crest-factor
³ Calculate from the sensitivity and power data

PM-15

2-Way, 15", High Power System

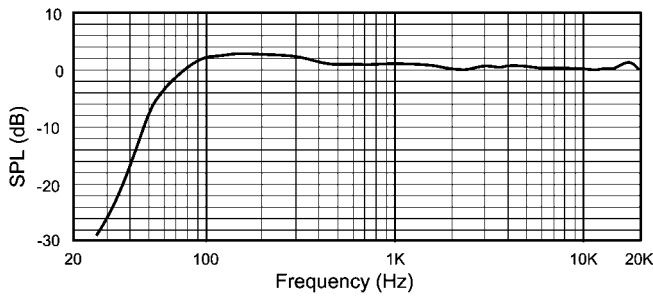

Normalized response (without processing - 2Π)

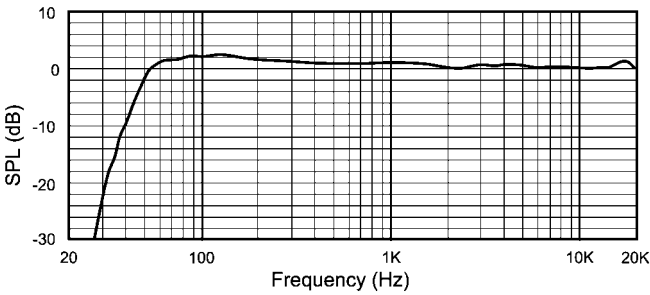

Normalized response (with processing - 2Π)

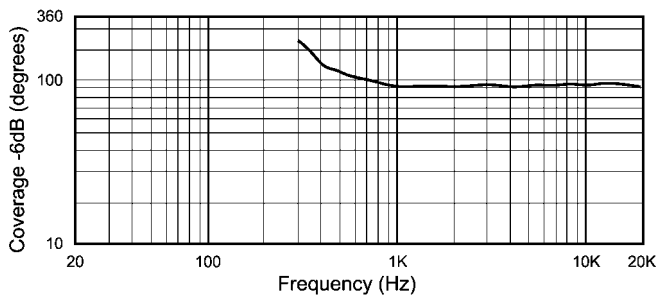

Horizontal coverage

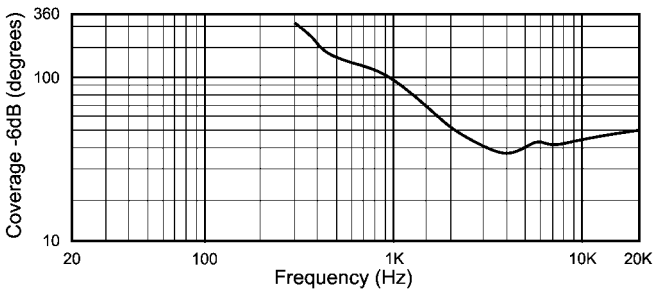

Vertical coverage



Handle & flying track detail



Back view



PM-15 in stand

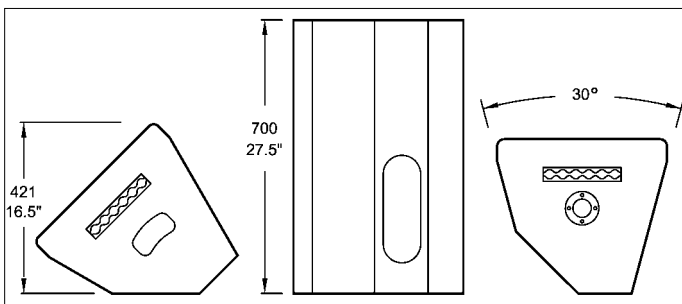

Flight case for two units



C.E. STUDIO 2 S.L.
 P.I. La Lloma, c/ Sierra Perenchiza 28
 46960 Aldaya - Valencia - Spain
 Phone: +34 96 1273054
 Fax: +34 96 1273056
<http://www.spaceequipmentaudio.com>
 e-mail: support@spaceequipmentaudio.com